

**Part Number: PT347-12161**

**Kit Contents**

Item #	Quantity Reqd.	Description
1	1	Convenience Net

**Recommended Sequence of Application**

Item #	Accessory

\*Mandatory

**Hardware Bag Contents**

Item #	Quantity Reqd.	Description

**Additional Items Required For Installation**

Item #	Quantity Reqd.	Description

**Conflicts**

None
------

**Recommended Tools**

<b>Personal &amp; Vehicle Protection</b>	<b>Notes</b>
None	
<b>Special Tools</b>	<b>Notes</b>
None	
<b>Installation Tools</b>	<b>Notes</b>
None	
<b>Special Chemicals</b>	<b>Notes</b>
None	

**General Applicability**

All 2017 and newer iM models
------------------------------

**Vehicle Service Parts** (may be required for reassembly)

Item #	Quantity Reqd.	Description

**Legend**



**STOP:** Damage to the vehicle may occur. Do not proceed until process has been complied with.



**OPERATOR SAFETY:** Use caution to avoid risk of injury.



**CAUTION:** A process that must be carefully observed in order to reduce the risk of damage to the accessory/vehicle and to ensure a quality installation.



**TOOLS & EQUIPMENT:** Used in Figures calls out the specific tools and equipment recommended for this process.



**REVISION MARK:** This mark highlights a change in installation with respect to previous issue.



**SAFETY TORQUE:** This mark indicates that torque is related to safety.

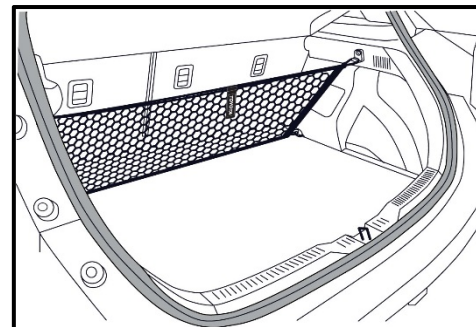

Care must be taken when installing this accessory to ensure damage does not occur to the vehicle. The installation of this accessory should follow approved guidelines to ensure a quality installation.

These guidelines can be found in the "Accessory Installation Practices" document.

This document covers such items as:-

- Vehicle Protection (use of covers and blankets, cleaning chemicals, etc.).
- Safety (eye protection, rechecking torque procedure, etc.).
- Vehicle Disassembly/Reassembly (panel removal, part storage, etc.).
- Electrical Component Disassembly/Reassembly (battery disconnection, connector removal, etc.).

Please see your dealer for a copy of this document.

1

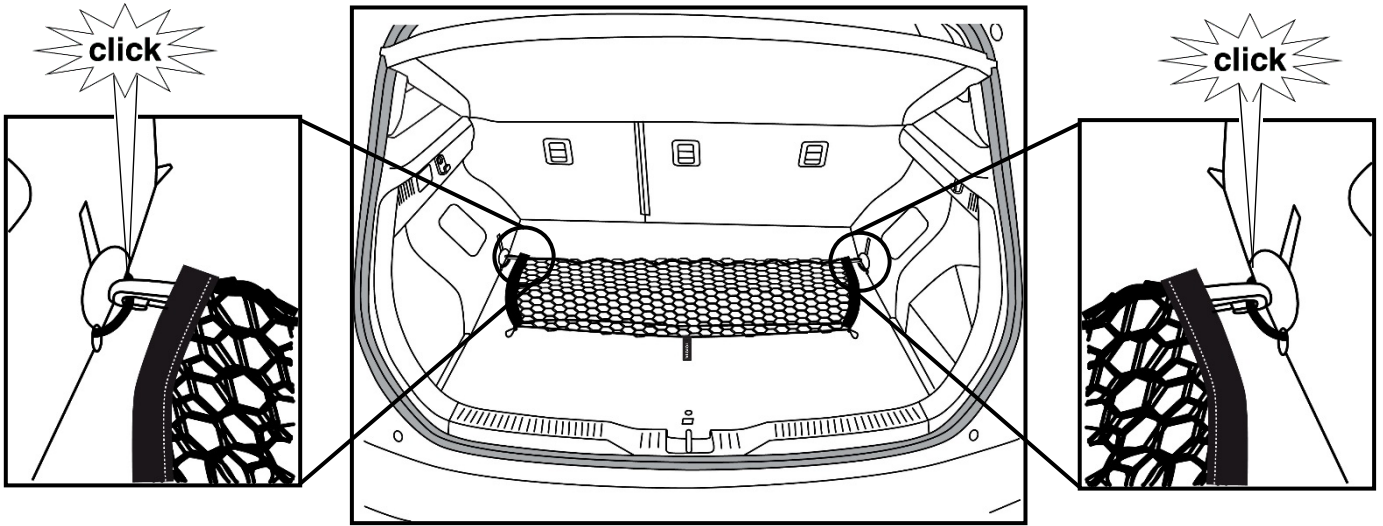

2

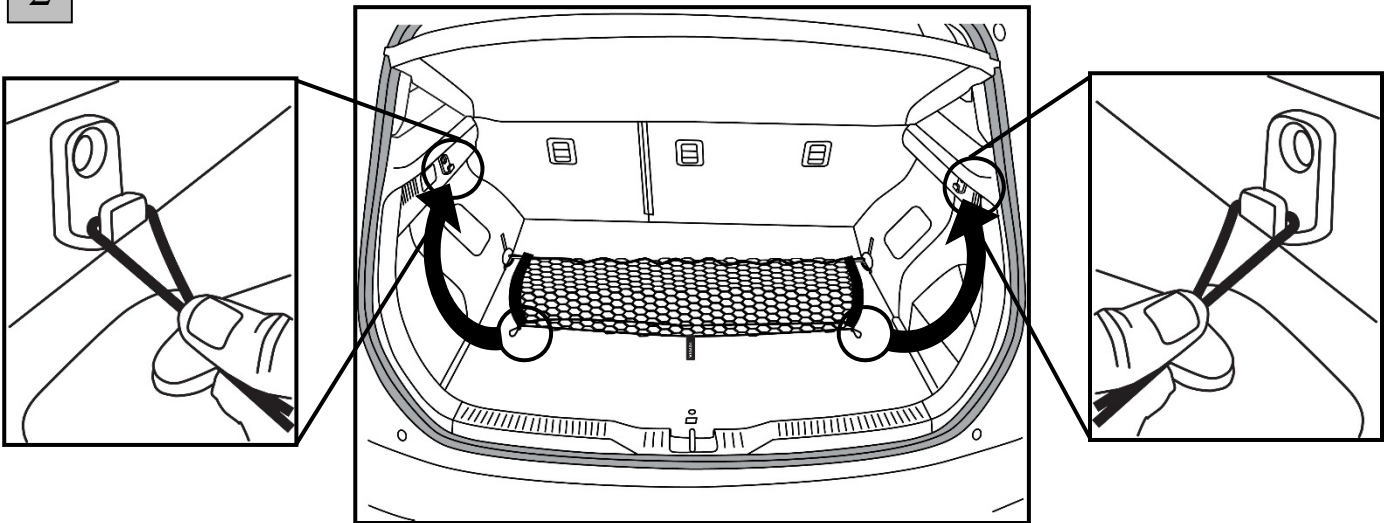

3

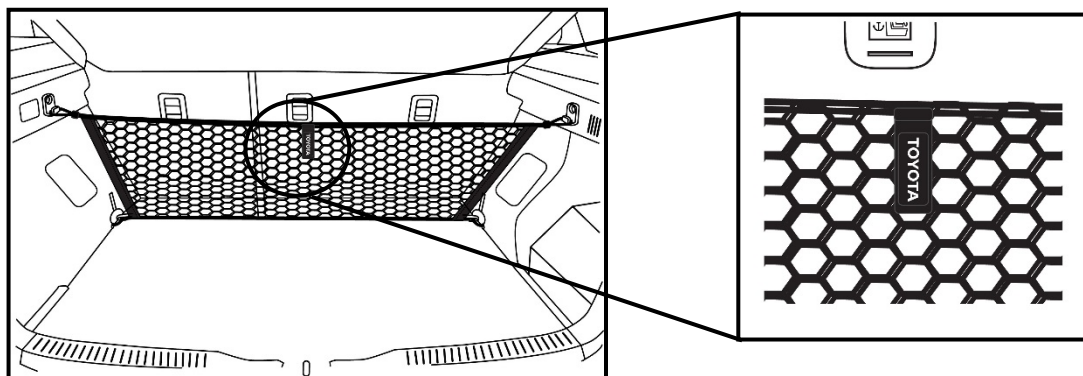

Checklist - these points **MUST** be checked to ensure a quality installation.

---

Accessory Function Checks

Confirm that the net is attached properly to the anchor points in the vehicle.

Confirm pull tab is facing toward the rear of the vehicle.

Confirm upper loops at the top of the net are attached to the upper L-Anchors of the vehicle.

Confirm the lower clips at the bottom of the net are attached to the lower D-Rings of the vehicle.

---

Vehicle Function Checks

Vehicle hatch door operation.

Confirm vehicle hatch door opens and closes without interference from Cargo Net.

---

Vehicle Appearance Check

After accessory installation and removal of protective cover(s), perform a visual inspection.

Ensure no damage (including scuffs and scratches) was caused during the installation process. (For PPO installations, refer to TMS Accessory Quality Shipping Standard.)